



The Scottish Country Dance Group Basel

Ball, 24th November 2018

Dance instructions

A RING OF FRIENDSHIP (J32), Round the room , 2 facing 2

Betty Grant, Laurel Collection

- 1- 8 All circle 4H round and back
- 9-16 All dance Ladies' Chain, finishing in promenade hold facing anticlockwise
- 17-24 All couples in prom hold dance interlocking 2 couple Promenade (anticlockwise, looping LSh round couple in next set and back to places)
- 25-32 All couples dance LA, turn opposite partner RH 1½ times to face new couple

A RING OF FRIENDSHIP		Round the room	8x32 J	
		ALL PROM Pass 2 Couples left shoulder Return to place	1 2 LA	

Betty Grant, 1982, Laurel Collection

2C/2C

GOOD HEARTED GLASGOW (J8x32) 3C (4C set)

Peter Knapman

- 1- 8 1st cpl turn RH and cast to 2nd place, turn partner LH 1¼ times to end man facing down and lady facing up
- 9-16 1st cpl dance RA (lady with 2nd cpl, man with 3rd cpl), 1st cpl pass R shoulder and dance LA with other cpl
- 17-24 1st cpl lead down the middle and back to 2nd place on own side
- 25-32 2s+1s+3s circle 6 hands round and back. Finish in the order 213

GOOD HEARTED GLASGOW				8x32 J	
					2 1 3

Peter Knapman, 1988, Collins Pocket Reference

3C/4C longwise set.

THE WESTMINSTER REEL (R8x32) 2C (4C set)

Jeremy Hill, RSCDS Book 45

- 1- 8 1st man and 2nd lady turn RH once round, 1st lady and 2nd man turn RH 1½ times and end facing partner ready for a diagonal reel of 4
- 9-16 Diagonal reel of 4, finish in original places
- 17-24 1st and 2nd cpls Set&Rotate:-
All set facing diagonally in, rotate singly and dance on 1 place clockwise, change places with partner up and down giving RH and dance on 1 place to own sides (1st cpl end in 2nd place)
- 25-32 2nd and 1st cpls dance R&L

THE WESTMINSTER REEL			8x32 R		
					2 1 RL

Jeremy Hill, London Jubilee Book, RSCDS Book 45.1

2C/4C longwise set.

THE BANKS OF CLYDE (S8x32) 3C (4C set)

MMM 1

- 1- 8 1st cpl followed by 2nd and 3rd cpls cast off on own sides, all cross giving RH below 3rd place and dance up the other side
- 9-16 1st, 2nd and 3rd cpls advance and retire, cross back to own sides giving RH and set
- 17-24 1s lead down the middle and back
- 25-32 1s+2s dance the Rondel

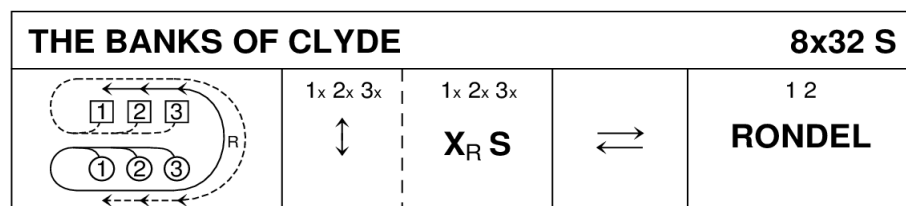

RSCDS MMM 1.4

3C/4C longwise set.

CITY LIGHTS (J8x32) 3C (4C set)

Nicola Scott, RSCDS Book 52

- 1-8 1st cpl turn RH, cast off 1 place and turn LH to face 1st corners (2s step up bars 3-4)
- 9-16 1st cpl dance R shoulders around 1st corners, then turn LH 1½ times to face 2nd corner positions WHILE 1st corners (2nd man and 3rd lady) dance in for lady to turn under man's arm (RH to RH), 2nd man retires as 3rd lady dances back to place facing out, and all corners (2M2L 3L3M) chase clockwise halfway round in 4 bars (to end 3rd cpl in 1st place on opposite sides, 2nd cpl in 3rd place on opposite sides and 1st cpl in the centre)
- 17-24 1st cpl dance R shoulder around 2nd corner positions, turn LH 1½ times to end in the centre, L shoulder to L shoulder (facing opposite sides) WHILE 2nd corners (2nd lady and 3rd man) dance in for lady to turn under man's arm (RH to RH), 3rd man retires as 2nd lady dances back to place facing out, and all corners chase clockwise halfway round in 4 bars (to end 2nd and 3rd cpls on own sides, 2s in first place)
- 25-32 1st lady with 2s, 1st man with 3s dance RA; all 3 cpls turn RH or birl

THE PLANTATION REEL (R5x32) 5C set

Tony Moretti, Pinewoods Collection 2

- 1- 8 1st and 3rd cpls cross RH and cast off 1 place, lead down between the couple below and cast back up to 2nd and 4th place (opposite sides)
- 9-16 2nd and 1st cpls, 4th and 3rd cpls dance ½ RL, then petronella turn 2 places anticlockwise round the square (end in same places as at bar 8)
- 17-24 All dance RA across (1st man with 2s, 1st lady and 3rd man with 4s, 3rd lady with 5s), then 1st and 3rd cpls change places with partners to dance LA
- 25-32 1st and 3rd cpls cross giving RH, cast off 1 place and all turn with R hands once round

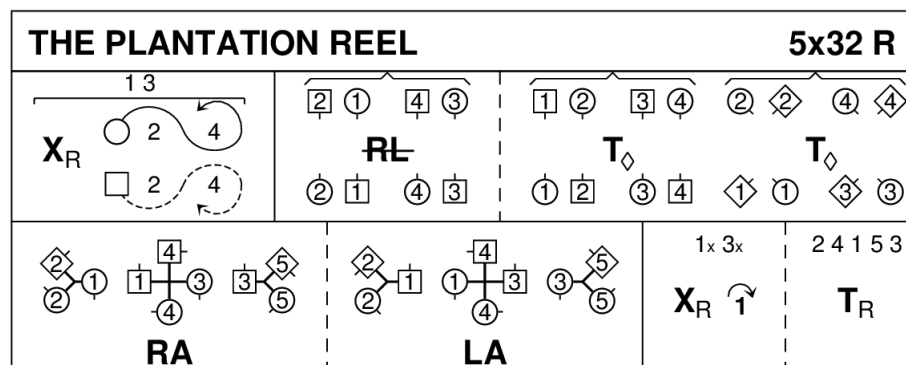

Tony Moretti, Pinewoods 2

5C/5C longwise set

TEACHER'S CHOICE

FUGAL FERGUS (J8x48) 3C (4C set)

Hugh Foss Waverley Fugues

Fugue dance; Men copy Ladies 8 bars later

- 1- 8 1st lady followed by 2nd and 3rd ladies dance anticlockwise round 1st, 2nd and 3rd men and back up to places (men stand)
- 9-16 1st, 2nd and 3rd ladies set and cross, set and cross back, while men dance clockwise round the set
- 17-24 1st, 2nd and 3rd ladies set and cross giving RH to partners, turn to the right and with 1st lady leading, dance clockwise across the set and down own side finishing 3,2,1 (while men set and cross back)
- 25-32 The 3 ladies dance a reel of 3 on own side (1st lady giving R shoulder to 2nd lady to start), while men set and cross below partners, dance up, across the set and down own side (to 3,2,1)
- 33-40 1st, 2nd and 3rd ladies dance another 1/2 reel of 3 on own side, then 1st and 2nd ladies turn with L hands 1 1/2 times to change places, while men dance their reel of 3 (1st and 2nd men pass L shoulders to begin)
- 41-48 Ladies stand while men finish the last fig.: 1/2 reel of three and 1st and 2nd men turn RH 1 1/2 times

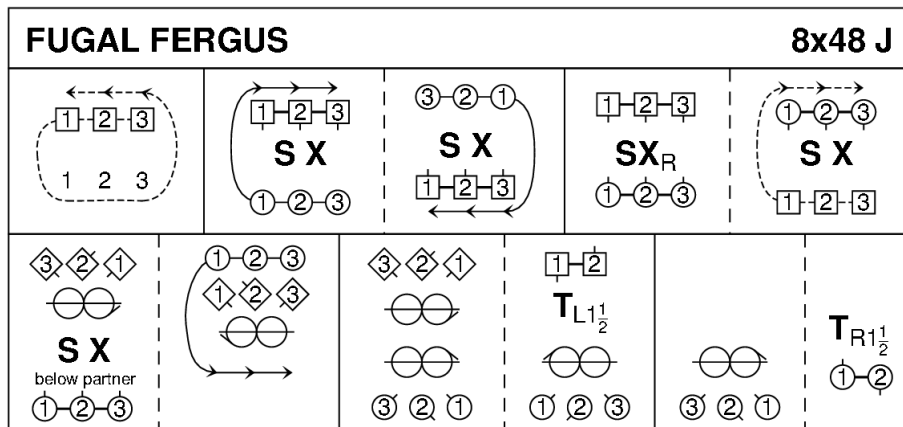

Hugh Foss, 1963, Waverley Fugues

3C/4C longwise set.

LE BON VIVEUR (M-S2x32+R2x32) Square.Set

I and C Brockbank

- 1- 8 All circle 8 hands round and back
 - 9-16 1st and 3rd cpls dance a Men's chain, finish with ladies facing out
 - 17-28 All dance Schiehallion reels (**for 12 bars**) to finish 1 place clockwise from starting place (4123)
 - 29-32 All birl (or turn) partners with R hands. Order 4123
- Note: Dance twice as Strathspey, twice as Reel

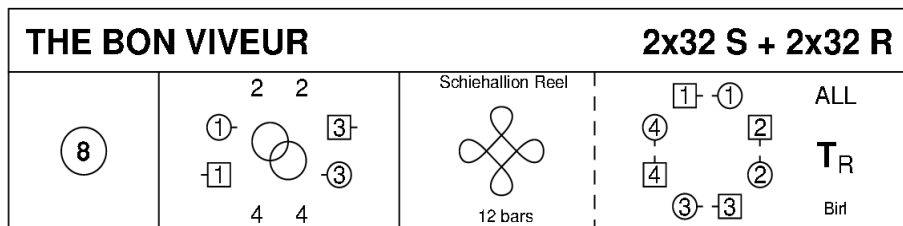

Ian Brockbank, 2015, RSCDS Book 52.11

4C/4C square set.

DANCING IN THE STREET (R4x32) 4C set

Tom Toriyama, RSCDS Book 42

- 1- 8 1st and 3rd cpls turn 3/4 with R hands, dance 1/2 reel of 4 in centre, 3s and 1s turn 3/4 RH to own sides. 3214
- 9-16 3rd and 2nd cpls, also 1st and 4th cpls dance RA and LA back (remain facing anticlockwise)
- 17-24 All chase halfway round the set and circle 8 hands round to right halfway, advancing to join hands for...
- 25-32 3rd and 2nd cpls, 1st and 4th cpls dance Poussette. Order 2341

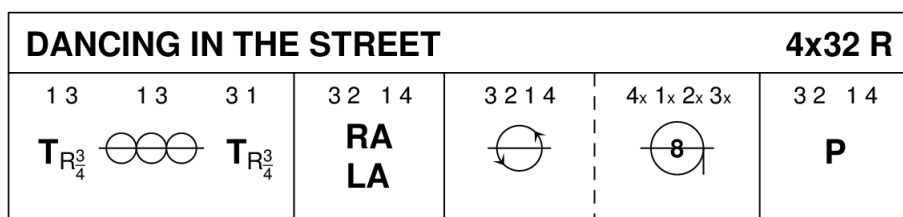

Tom Toriyama, RSCDS Book 42.4

4C/4C longwise set.

MISS ELEANOR (S3x32) 3C

Ann Dix, RSCDS Book 49

- 1- 8 1st, 2nd and 3rd cpls dance mirror reels of 3 on sides (1st cpl dance in and down to start)
- 9-16 1st cpl set, cast off (2s step up) and turn RH, then 1st lady casts to 3rd place, 1st man casts up to 1st place (2nd man steps down and 3rd lady steps up)
- 17-24 All dance a 3 couple Bourrel:-
 - 17-20 1st man and 3rd lady, also 2nd man and 1st lady set advancing and turn $\frac{3}{4}$ with 2H into a line up/down the middle of the set, then pull back R shoulders turning to face own partners while 3rd man and 2nd lady chase anticlockwise round to face them
 - 21-24 All set and turn with both hands to own sides. Order 312
- 25-32 3s+1s+2s circle 6 hands round and back

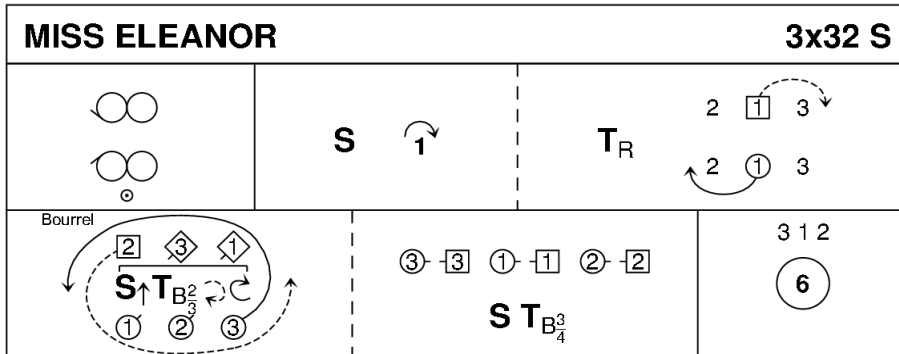

Ann Dix, 2013, RSCDS Book 49.5

3C/3C longwise set.

TEACHER'S CHOICE

THE COUNTESS OF DUNMORE'S REEL (R8x32) 3C (4C set)

Deirdre MacCuish Bark, RSCDS Book 49

- 1- 8 1st cpl set, dance down below 3rd cpl with nearer hands joined, cast up to 2nd place and set advancing to face 1st corners (2s step up 3-4)
- 9-16 1st cpl turn 1st corners RH, pass R shoulders, turn 2nd corners RH and pass R shoulders to finish in 2nd place on own side facing out (corners dance for 4 bars)
- 17-24 Promenade (Chaperoned) Chain progression:-
 - 17-18 1st man casts up, 1st lady casts off as 2nd and 3rd cpls turn $\frac{3}{4}$ with R hands into line up/down set
 - 19-22 1st man and 2nd lady, 1st lady and 3rd man, in promenade hold, dance clockwise to opposite end of the line while 2nd man and 3rd lady (in middle) turn $1\frac{1}{2}$ time with L hands
 - 23-24 1st cpl dance on clockwise to 2nd place on own side as 3s+2s turn partners $\frac{3}{4}$ RH back to own sides. All face clockwise. Order is 312
- 25-32 3rd, 1st and 2nd cpls dance clockwise halfway round the set. All set and cross giving RH to own sides. 213

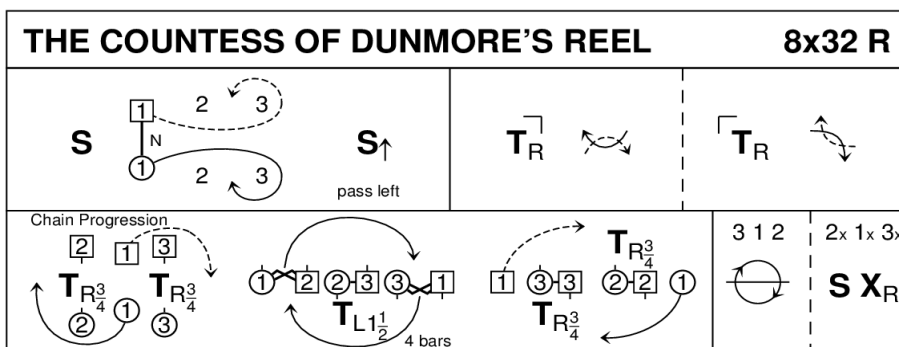

Deirdre MacCuish Bark, RSCDS Book 49.12

3C/4C longwise set.

ALLTSHELLACH (S8x32) 2C (4C set)

Elizabeth D Gilroy, RSCDS Book 23

- 1- 8 1st and 2nd cpls set to partners, turn with both hands once round and dance ½ Diamond Poussette
- 9-16 1st cpl followed by 2nd cpl lead down the middle and back to original places (2s divide and turn in behind 1s to dance back up)
- 17-24 1st and 2nd cpls dance reel of 4 across (1st lady and 2nd man passing L shoulders to start)
- 25-32 1st and 2nd cpls dance the Tournée:-
1s and 2s dance into prom hold (men with partner on right, 1st cpl face mens' side, 2nd cpl ladies' side), both couples wheel round anticlockwise halfway, men turn ladies into the middle so ladies face the mens' side and men the ladies' side. Both couples turn 1½ times (2s RH, 1s LH) and dance out to places

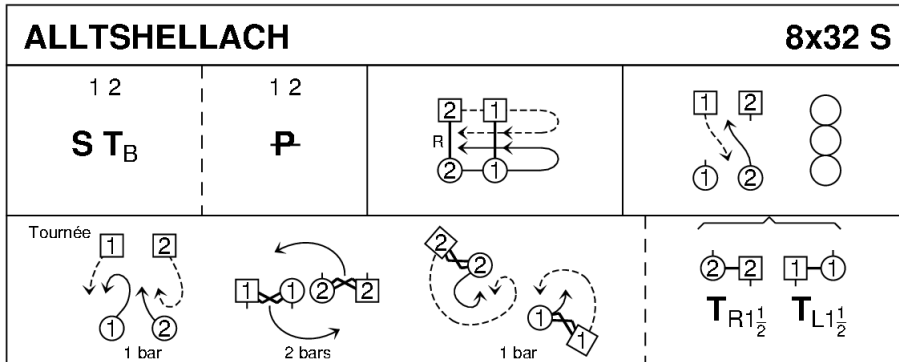

Elizabeth D Gilroy, RSCDS Book 23.2

2C/4C longwise set.

LES REMPARTS DE SÉVILLE (J8x32) 3C (4C set)

Aliénor Latour, RSCDS Book 50

- 1- 8 1st cpl set, cast off 1 place (2s step up bars 3-4), then dance a half figure of 8, 1st lady up through 2nd cpl, 1st man down through 3rd cpl
- 9-16 1st cpl turn LH to face 1st corners and dance set to corners and partner ('Hello-Goodbye') to end 1st man between 2nd cpl facing down, 1st lady between 3rd cpl facing up
- 17-24 2s+1s+3s Set&Link for three, all set, all cross giving R hands
- 25-32 2s+1s+3s circle 6 hands round and back

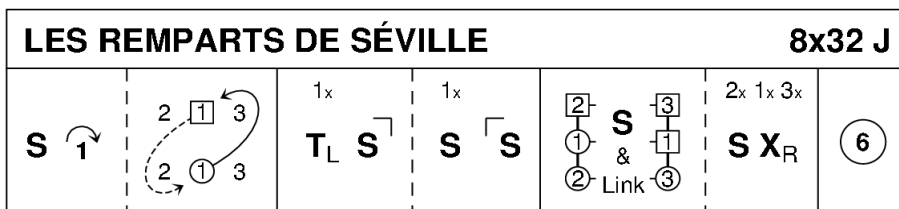

Aliénor Latour, 2014, RSCDS Book 50.2

3C/4C longwise set.

THE PIPER AND THE PENGUIN (R88) Sq.Set

Roy Goldring, Scotia Suite

- 1- 8 All 4 ladies dance R shoulder round their corners, then dance RA remaining in centre
- 9-16 Ladies dance L shoulder round their partners, dance LA in the centre and return to places
- 17-24 All 4 men dance R shoulder round their partners, dance RA remaining in centre
- 25-32 Men dance L shoulder round their corners, dance LA in the centre and back to places
- 33-40 1st and 3rd cpls turn partners RH 1¼ times, the men followed by their partners dance out between the side couples and back to places (1st man through 4s and 3rd man through 2s)
- 41-48 1st and 3rd cpls dance R&L
- 49-56 2nd and 4th cpls repeat the last 16 bars: turn partners RH 1¼ times, the men followed by partners dance out between the top couples and back to places (2nd man through 1s and 4th man through 3s)
- 57-64 2nd and 4th cpls dance R&L
- 65-72 Ladies dance into centre turning right about to dance out and chase clockwise to opposite lady's place
- 73-80 Men dance into centre turning left about to dance out and chase anticlockwise to opposite places
- 81-88 All turn partners RH 1¼ times into prom hold, Promenade anticlockwise halfway round to original places

THE PIPER AND THE PENGUIN				88 R	
1 3 T_{R1 1/4}		1 3 RL	2 4 R 16 bars		
		ALL T_{R1 1/4}	PROM anticlockwise		

Roy Goldring, 2002, Scotia Suite

4C/4C square set.

THE FLOWER OF GLASGOW (S3x32) 3C set

Ruth Taylor, RSCDS Book 46

- 1- 8 1st lady followed by partner casts off 2 places, 1st lady crosses and casts up round 3rd man to 2nd place on men's side while 1st man dances up the middle to 2nd place on the ladies' side. All set advancing into promenade hold (2s and 3s face up, 1s facing down). Order 2(1)3
- 9-16 2s+1s+3s dance a Circulating Allemande:-
2nd and 3rd cpls dance a normal Allemande ending in 3rd/1st place while 1st cpl dance the Allemande down the way to begin and up to 2nd place opposite sides. 3(1)2
- 17-24 1st cpl dance 1/2 figures of 8 (1st lady up round 3s, 1st man down round 2s), all turn partners 2H. Order 312
- 25-32 1st and 2nd cpls dance a Diamond Poussette

THE FLOWER OF GLASGOW			3x32 S		
	2 1 x 3 S			3 1 2 T_B	1 2 P

Ruth Taylor, 2004, RSCDS Book 46.9

3C/3C longwise set.

REEL OF THE 51ST DIVISION (R8x32) 3C (4C set)

Atkinson, RSCDS Book 13

- 1- 8 1st cpl set and cast off 2 places to below 3rd cpl and lead up to face 1st corners
- 9-16 1st cpl set and turn 1st corners RH to balance-in-line position, set and 1s turn LH to face 2nd corners
- 17-24 1st cpl set and turn 2nd corners RH to balance-in-line-position, set and 1s turn LH to 2nd place own sides
- 25-32 2nd, 1st and 3rd cpls circle 6 hands round and back

THE REEL OF THE 51st DIVISION			8x32 R	
S	S T_R B T_{L1 1/4}	S T_R B T_L	2 1 3	

Jimmy Atkinson & Peter Oliver, 1940, RSCDS Book 13.10

3C/4C longwise set.

EXTRAS

SCOTT MEIKLE (R4x32) 4C set

Alice McLean, RSCDS Book 46

- 1- 8 1st cpl cross giving RH and cast to 2nd place, 1st cpl dance ½ figure of 8 round 2nd cpl
- 9-16 1st and 3rd cpls dance RA and LA back
- 17-24 1st lady followed by 3rd lady dance a Tandem reel of 3 across the dance with 2s (L shoulder to 2nd man) while 3rd man followed by 1st man dance a Tandem reel of 3 with 4s (L shoulder to 4th lady). 1st cpl end 3rd place, 3rd cpl end in 2nd place. 2314
- 25-32 1st and 4th cpls dance ½ R&L and turn partners with R hands 1½ times. 2341

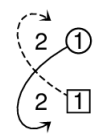
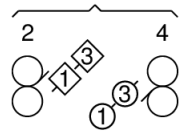
SCOTT MEIKLE				4x32 R	
$X_R \curvearrowright 1$		1 3 RA LA		1 4 RL	4x 1x T_R1½

Alice McLean, Laurieston Collection 1, RSCDS Book 46.3

4C/4C longwise set.

J. B. MILNE (R8x32) 3C (4C set)

Hugh Foss Angus Fitchett Album

- 1- 8 1st man and 2nd lady set advancing and turn RH, 1st lady and 2nd man set advancing and turn RH
- 9-16 1st cpl set to each other and turn with both hands, cast to 2nd place and petronella turn to finish lady between 2s facing down and man between 3s facing up
- 17-24 1st cpl set and turn ¾ RH while 2s+3s change places giving RH on the sides and set, 1st cpl set and turn ¾ while 2nd and 3rd cpls cross giving RH and set
- 25-32 1st cpl set and change places RH up and down while 2s+3s change places giving RH on sides and set, then 1st cpl cast to the right round corner to 2nd place on own sides as 2s+3s cross giving RH and all set

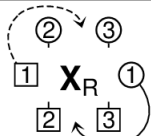
J. B. MILNE			8x32 R	
$\boxed{2}$ S ↑ T_R ①	$\boxed{1}$ S ↑ T_R ②	S ↑ T_B \curvearrowright T_◇	$\overbrace{1 \quad \boxed{2} \quad \boxed{3}}$ ST_R¾ X_R S ② ③	
$\overbrace{1x \quad 3 \quad 2}$ ST_R¾ X_R S	$\overbrace{1 \quad \boxed{3} \quad \boxed{2}}$ S X_R X_R S $\boxed{3}$ $\boxed{2}$	 2 1 3 S		

Hugh Foss, 1954, Angus Fitchett S D Album

3C/4C longwise set.